

**VLASTNOSTI**

- PREVODNÍK+BUS
- Vstup DC: 12-24-48 Vdc
- Príkaz BUS: DMX alebo DALI
- Prevodník z protokolu DALI na protokol DMX
- Prevodník z protokolu DMX na protokol DALI
- Možnosť ovládať zariadenie s protokolom DALI pomocou protokolu DMX a naopak
- Rozšírený teplotný rozsah
- 100 % funkčná skúška – 5-ročná záruka

→ Celý a aktualizovaný **návod k zariadeniu** nájdete na webovej stránke výrobcu: <http://www.dalcnet.com>

➤ **KÓD PRODUKTU**

KÓD	Vstupné napätie	Kanál	Vstupný príkaz	Výstupný príkaz	
DGD-DMX-DALI1	12-48 V DC	1	DMX	DALI	PREVODNÍK
DGD-DALI-DMX	12-48 V DC	1	DALI	DMX	PREVODNÍK

➤ **OCHRANY**

OVP	Ochrana proti prepätí ²		✓
UVP	Ochrana proti podpäť ²		✓
RVP	Ochrana proti prepólovaniu ²		✓
IFP	Ochrana vstupnej poistky ²		✓

¹ Vyžaduje napájanie v zbernici DALI

² Iba ochrana riadiacej logiky



➤ ODKAZOVACIE NORMY

EN 61347-1	Ovládacie zariadenia svietidiel – Časť 1: Všeobecné a bezpečnostné požiadavky
EN 55015	Limity a metódy merania charakteristík rádiového rušenia elektrických osvetľovacích a podobných zariadení
EN	Zariadenia na všeobecné osvetlenie – Požiadavky na odolnosť proti elektromagnetickému rušeniu

➤ TECHNICKÁ ŠPECIFIKÁCIA

		Konštantné napätie	
Napájacie napätie		min: 10,8 Vdc .. max: 52,8 Vdc	
Menovitý výkon ³		Variant DMX-DALI Typ	Variant DALI-DMX Min Max
	@12V	101 mW	100 mW 184 mW
	@24V	161 mW	156 mW 248 mW
	@48 V	274 mW	279 mW 380 mW
Strata výkonu v pohotovostnom režime		<500 mW	
Skladovacia teplota		min: -40 max: +60 °C	
Okolité teplota ³		min: -10 max: +40 °C	
Stupeň ochrany		IP10	
Zapojenie		2,5 mm ² pevný – 2,5 mm ² lankový – 30/12 AWG	
Dĺžka prípravy vodiča		5,5 – 6,5 mm	
Mechanické rozmery		92 x 36 x 62 mm DIN RAIL 2M	
Rozmery balenia		124 x 71 x 48 mm	
Materiál obalu		Plast	
Hmotnosť		90 g	

³ Maximálna hodnota, závislá od podmienok vetrania.



➤ INŠTALÁCIA

Pri inštalácii postupujte podľa nižšie uvedeného náčrtu:

- 1) Pripojte zbernicu k svorkovnici zariadenia (v závislosti od variantu DGD).
- 2) Pripojte napájanie (12–48 V DC) k svorkovniciam zariadenia „DC IN“.

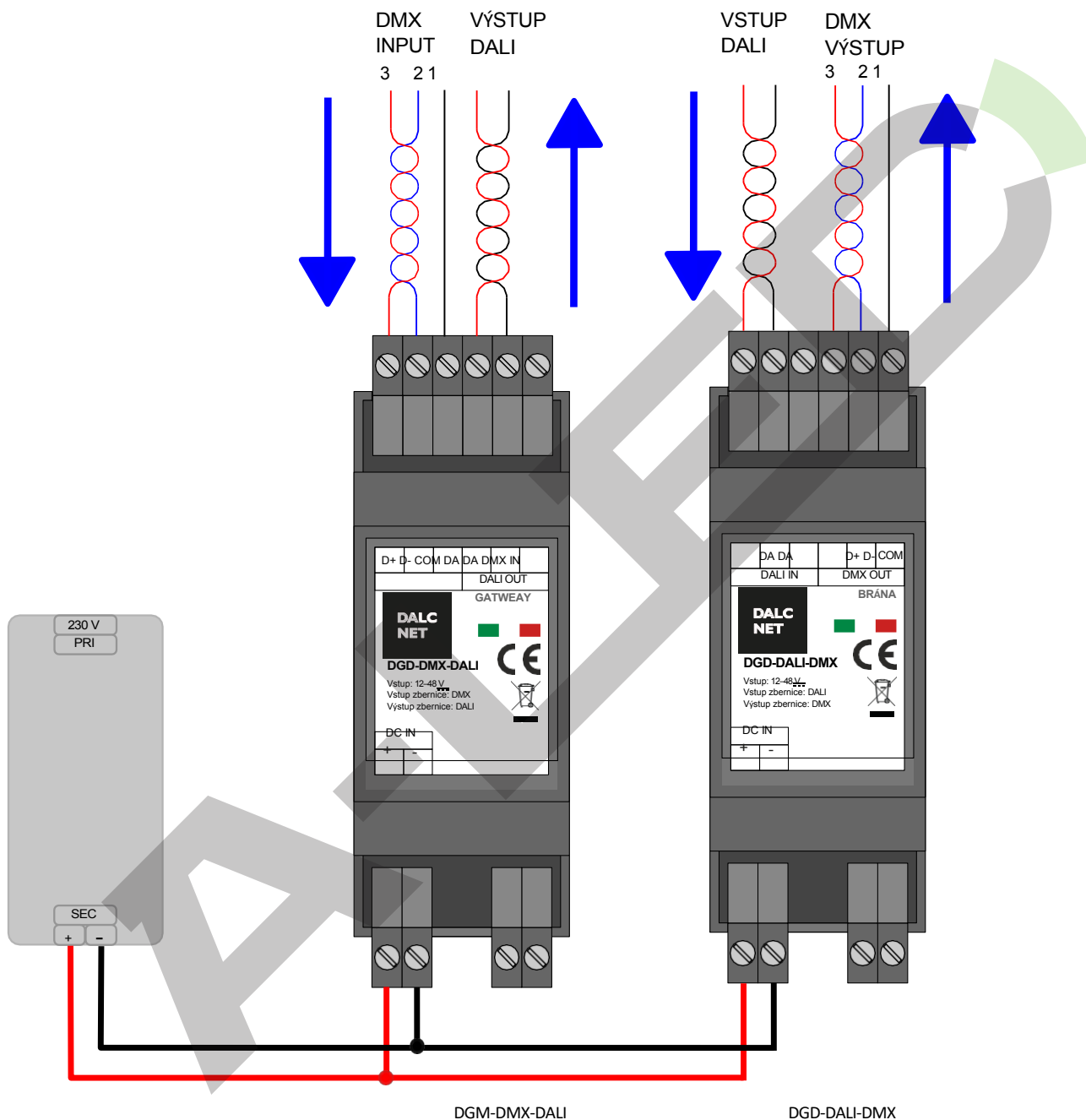

➤ MECHANICKÉ ROZMERY (bez koncoviek)

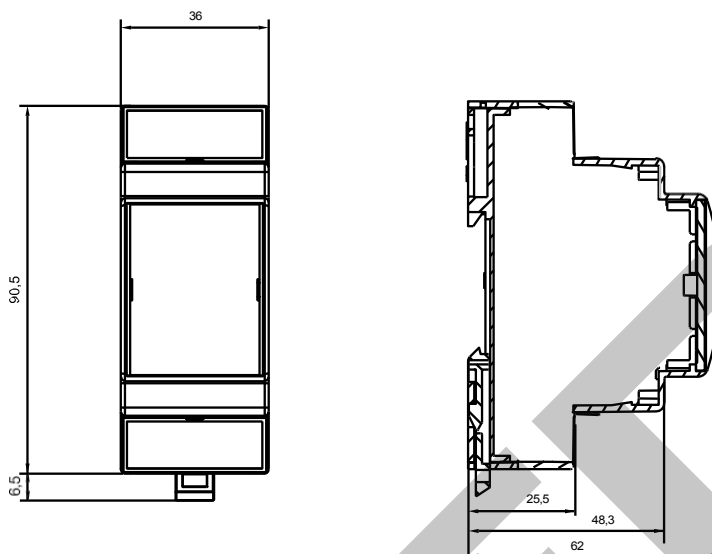

➤ TECHNICKÉ POZNÁMKY

Inštalácia:

- Inštaláciu a údržbu smie vykonávať iba kvalifikovaný personál v súlade s platnými predpismi.
- Produkt musí byť inštalovaný vo vnútri elektrického panela chráneného proti prepätiu.
- Produkt sa musí inštalovať vo vertikálnej alebo horizontálnej polohe s krytom/etikou smerom nahor alebo vertikálne; iné polohy nie sú povolené. Nie je povolená poloha zdola nahor (s krytom/etikou smerom nadol).

• Oddelte obvody s napätím 230 V (LV) a obvody, ktoré nie sú SELV, od obvodov s nízkym napätím (SELV) a od akéhokoľvek pripojenia k tomuto produktu. Je prísne zakázané pripájať z akéhokoľvek dôvodu priamo alebo nepriamo sieťové napätie 230 V k zbernici alebo iným častiam obvodu.

Napájanie:

- Na napájanie používajte iba napájacie zdroje SELV s obmedzeným prúdom, ochranou proti skratu a správne dimenzovaným výkonom. V prípade použitia napájacieho zdroja s uzemňovacími svorkami musia byť všetky body ochranného uzemnenia (PE = Protection Earth) pripojené k platnému a certifikovanému ochrannému uzemneniu.
- Pripojovacie káble medzi zdrojom napájania „nízke napätie“ a produktom musia byť správne dimenzované a mali by byť izolované od všetkých vodičov alebo častí s napätím, ktoré nie je SELV. Používajte káble s dvojitou izoláciou.
- Dimenzujte napájanie pre zaťaženie pripojené k zariadeniu. Ak je napájanie predimenzované v porovnaní s maximálnym odoberaným prúdom, vložte medzi napájanie a zariadenie ochranu proti nadprúdu.

Príkaz:

- Dĺžka a typ pripojovacích káblov na zbernici (DMX512, DALI alebo iné) používajú káble podľa špecifikácie príslušných protokolov a predpisov a mali by byť izolované od každého vedenia alebo častí s napätím, ktoré nie je SELV. Odporúča sa používať dvojito izolované tienené a skrútené káble.
- Všetky produkty a riadiace signály pripojené na zbernicu (DMX512, DALI alebo iné) musia byť SELV (pripojené zariadenia musia byť SELV alebo dodávať signál SELV).

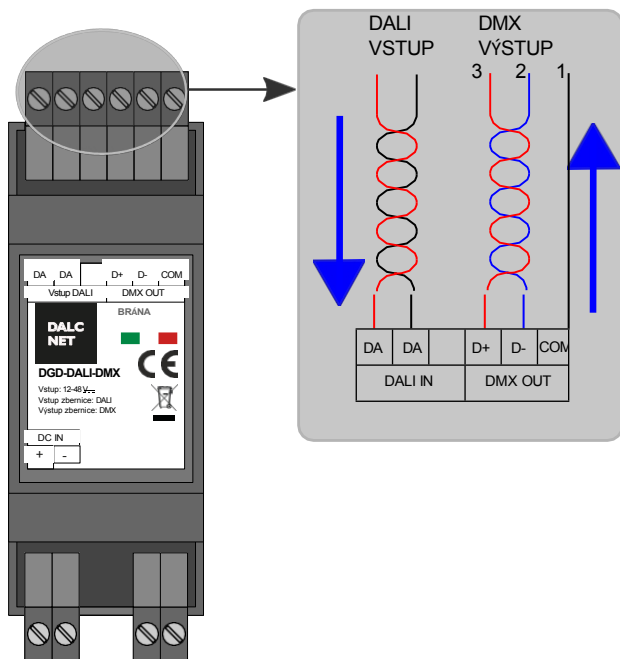
➤ **NASTavenie DGD-DALI-DMX – PREVOD Z PROTOKOLU DALI NA PROTOKOL DMX****Signálová LED:**

V prípade, že nie je detegované napájanie zbernice alebo došlo k chybe zbernice, LED dióda bliká rýchlo (2 impulzy za sekundu). V prípade, že je napájanie zbernice, ale nie sú k dispozícii žiadne dáta, LED dióda bliká pomaly (1 impulz za sekundu).

V prípade aktívneho dátového spojenia svieti LED dióda nepretržite.

Prevod

DGD-DALI-DMX konvertuje všetkých 64 adries DALI na 64 kanálov DMX.

DGD-DALI-DMX prevádza protokol DALI na protokol DMX, ale nie naopak.

Zariadenie nespravuje adresovanie zbernice DALI. Adresy DALI od 0 do 63 sú pevne nastavené a odosiela sa do kanála DMX od 1 do 64.

Implementované príkazy sú: VYPNÚŤ, HORE, DOLE, KROK HORE, KROK DOLE, PRIAME NAPÁJANIE OBLÚKA, VYVOLANIE MINIMÁLNEJ ÚROVNE, VYVOLANIE MAXIMÁLNEJ ÚROVNE,

GOTO LAST ACTIVE LEVEL. Hodnoty príkazov sa neukladajú, ak nie je prítomné napájacie napätie.

Prevodná tabuľka adries DALI na kanály DMX:

Addr DALI	Kanál DMX	Adresa DALI	Kanál DMX	Addr DALI	Kanál DMX	Addr DALI	Kanál DMX	Addr DALI	Kanál DMX	Addr DALI	Kanál DMX
+0	⇨	1		+11	⇨	12		+22	⇨	23	
+1	⇨	2		+12	⇨	13		+23	⇨	24	
+2	⇨	3		+13	⇨	14		+24	⇨	25	
+3	⇨	4		+14	⇨	15		+25	⇨	26	
+4	⇨	5		+15	⇨	16		+26	⇨	27	
+5	⇨	6		+16	⇨	17		+27	⇨	28	
+6	⇨	7		+17	⇨	18		+28	⇨	29	
+7	⇨	8		+18	⇨	19		+29	⇨	30	
+8	⇨	9		+19	⇨	20		+30	⇨	31	
+9	⇨	10		+20	⇨	21		+31	⇨	32	
+10	⇨	11		+21	⇨	22		+32	⇨	33	
								+33	⇨	34	
								+34	⇨	35	
								+35	⇨	36	
								+36	⇨	37	
								+37	⇨	38	
								+38	⇨	39	
								+39	⇨	40	
								+40	⇨	41	
								+41	⇨	42	
								+42	⇨	43	
								+43	⇨	44	
								+44	⇨	45	
								+45	⇨	46	
								+46	⇨	47	
								+47	⇨	48	
								+48	⇨	49	
								+49	⇨	50	
								+50	⇨	51	
								+51	⇨	52	
								+52	⇨	53	
								+53	⇨	54	
								+54	⇨	55	
								+55	⇨	56	
								+56	⇨	57	
								+57	⇨	58	
								+58	⇨	59	
								+59	⇨	60	
								+60	⇨	61	
								+61	⇨	62	
								+62	⇨	63	
								+63	⇨	64	

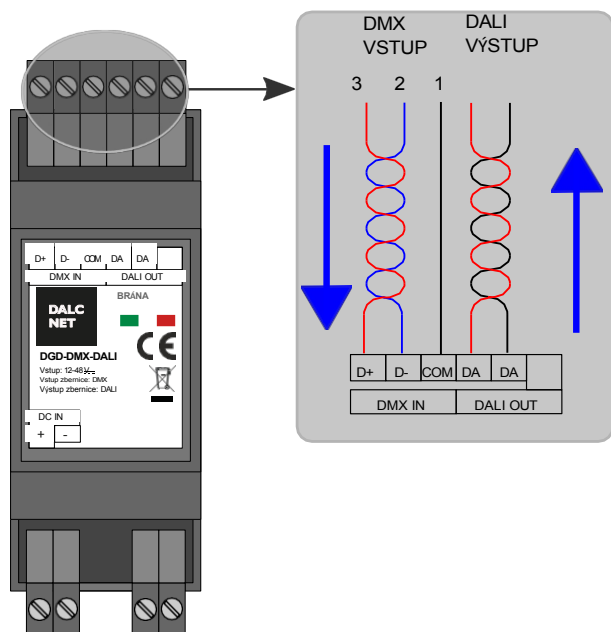
➤ **NASTAVENIE DGD-DMX-DALI – PREVOD Z PROTOKOLU DMX NA PROTOKOL DALI****Signálna LED:**

V prípade chyby zbernice LED bliká rýchlo (2 impulzy za sekundu).
V prípade, že nie je detegovaná zbernica, LED bliká pomaly (1 impulz za sekundu). V prípade aktívneho dátového prepojenia LED svieti.

Prevod

Prevodník DGD-DMX-DALI prevádza iba prvých 64 kanálov DMX na 64 adres DALI.
Prevodník DGD-DMX-DALI prevádza protokol DMX na protokol DALI, ale nie naopak.
Kanály DMX od 1 do 64 sú pevne nastavené a sú odosielané na adresy DALI od 0 do 63 pomocou príkazu DIRECT ARC POWER.

POZNÁMKA: DGD-DMX-DALI vyžaduje napájanie v zbernici DALI. Zariadenia DALI musia byť adresované prostredníctvom programátora DALI (napríklad s kódom DGM01-1248).

Prevodná tabuľka z kanálov DMX na adresy DALI

Kanál DMX	Adresa DALI	Kanál DMX	Addr DALI	Kanál DMX	Addr DALI	Kanál DMX	Addr DALI	Kanál DMX	Addr DALI	Kanál DMX	Addr DALI
1	⇨ +0	12	⇨ +11	23	⇨ +22	34	⇨ +33	45	⇨ +44	56	⇨ +55
2	⇨ +1	13	⇨ +12	24	⇨ +23	35	⇨ +34	46	⇨ +45	57	⇨ +56
3	⇨ +2	14	⇨ +13	25	⇨ +24	36	⇨ +35	47	⇨ +46	58	⇨ +57
4	⇨ +3	15	⇨ +14	26	⇨ +25	37	⇨ +36	48	⇨ +47	59	⇨ +58
5	⇨ +4	16	⇨ +15	27	⇨ +26	38	⇨ +37	49	⇨ +48	60	⇨ +59
6	⇨ +5	17	⇨ +16	28	⇨ +27	39	⇨ +38	50	⇨ +49	61	⇨ +60
7	⇨ +6	18	⇨ +17	29	⇨ +28	40	⇨ +39	51	⇨ +50	62	⇨ +61
8	⇨ +7	19	⇨ +18	30	⇨ +29	41	⇨ +40	52	⇨ +51	63	⇨ +62
9	⇨ +8	20	⇨ +19	31	⇨ +30	42	⇨ +41	53	⇨ +52	64	⇨ +63
10	⇨ +9	21	⇨ +20	32	⇨ +31	43	⇨ +42	54	⇨ +53		
11	⇨ +10	22	⇨ +21	33	⇨ +32	44	⇨ +43	55	⇨ +54		

**FEATURES**

- CONVERTER+BUS
- DC Input: 12-24-48 Vdc
- BUS Command: DMX o DALI
- Converter from DALI protocol to DMX protocol
- Converter from DMX protocol to DALI protocol
- Possibility to control device with protocol DALI by protocol DMX and viceversa
- Extended temperature range
- 100% Functional Test – 5 Years warranty

→ For the whole and update **Device Manual** refer to producer's website: <http://www.dalcnet.com>

➤ **PRODUCT CODE**

CODE	Input Voltage	Channel	Input command	Output command	
DGD-DMX-DALI ¹	12-48V DC	1	DMX	DALI	CONVERTER
DGD-DALI-DMX	12-48V DC	1	DALI	DMX	CONVERTER

➤ **PROTECTIONS**

OVP	Over voltage protection ²		✓
UVP	Under voltage protection ²		✓
RVP	Reverse polarity protection ²		✓
IFP	Input fuse protection ²		✓

¹ It requires power supply in the DALI bus

² Only control logic protection



➤ REFERENCE STANDARDS

EN 61347-1	Lamp controlgear – Part 1: General and safety requirements
EN 55015	Limits and methods of measurement of radio disturbance characteristics of electrical lighting and similar equipment
EN 61547	Equipment for general lighting purpose – EMC immunity requirements

➤ TECHNICAL SPECIFICATION

		Constant Voltage	
Supply Voltage		min: 10,8 Vdc .. max: 52,8 Vdc	
Nominal Power ³		DMX-DALI Variant Typ	DALI-DMX Variant Min Max
	@12V	101 mW	100 mW 184 mW
	@24V	161 mW	156 mW 248 mW
	@48V	274 mW	279 mW 380 mW
Power loss in stand by mode		<500mW	
Storage Temperature		min: -40 max: +60 °C	
Ambient Temperature ³		min: -10 max: +40 °C	
Protection grade		IP10	
Wiring		2.5mm ² solid – 2.5mm ² stranded – 30/12 AWG	
Wire preparation length		5,5 – 6,5 mm	
Mechanical dimensions		92 x 36 x 62 mm DIN RAIL 2M	
Package dimension		124 x 71 x 48 mm	
Casing material		Plastic	
Weight		90g	

³ Maximum value, dependent on ventilation conditions.

➤ INSTALLATION

Follow the drawing below to set the product:

- 1) Connect the BUS at terminal block of the device (depending on the DGD variant).
- 2) Connect the power supply (12-48Vdc) to the device terminal blocks "DC IN".

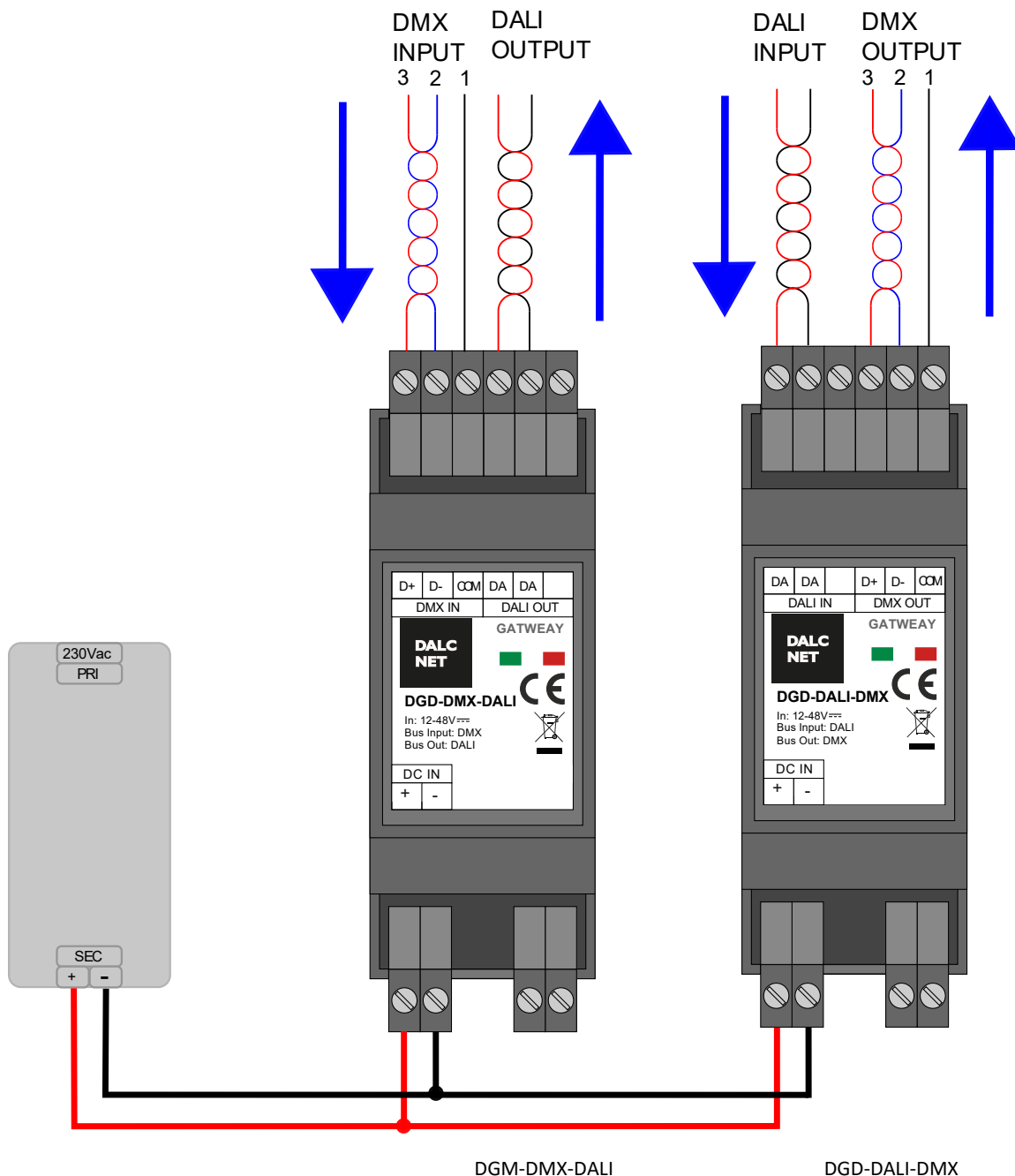

➤ **MECHANICAL DIMENSION**
(terminals excluded)

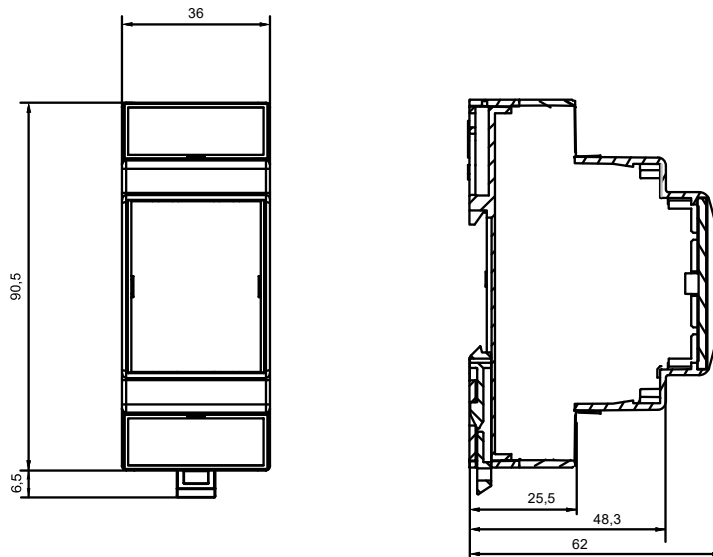

➤ **TECHNICAL NOTES**

Installation:

- Installation and maintenance must be performed only by qualified personnel in compliance with current regulations.
- The product must be installed inside an electrical panel protected against overvoltages.
- The product must be installed in a vertical or horizontal position with the cover / label upwards or vertically; Other positions are not permitted. It is not permitted to bottom-up position (with the cover / label down).
- Keep separated the circuits at 230V (LV) and the circuits not SELV from circuits to low voltage (SELV) and from any connection with this product. It is absolutely forbidden to connect, for any reason whatsoever, directly or indirectly, the 230V mains voltage to the bus or to other parts of the circuit.

Power Supply:

- For the power supply use only a SELV power supplies with limited current, short circuit protection and the power must be dimensioned correctly. In case of using power supply with ground terminals, all points of the protective earth (PE = Protection Earth) must be connected to a valid and certified protection earth.
- The connection cables between the power source "low voltage" and the product must be dimensioned correctly and they should be isolated from every wiring or parts at voltage not SELV. Use double insulated cables.
- Dimension the power supply for the load connected to the device. If the power supply is oversized compared with the maximum absorbed current, insert a protection against over-current between the power supply and the device.

Command:

- The length and type of the connection cables at the BUS (DMX512, DALI or other) use cables as per specification of the respective protocols and regulations and they should be isolated from every wiring or parts at voltage not SELV. It is suggested to use double insulated shielded and twisted cables.
- All the product and the control signal connect at the bus (DMX512, DALI or other) must be SELV (the devices connected must be SELV or supply a SELV signal)

➤ DGD-DALI-DMX SETUP – CONVERSION FROM DALI PROTOCOL TO DMX PROTOCOL

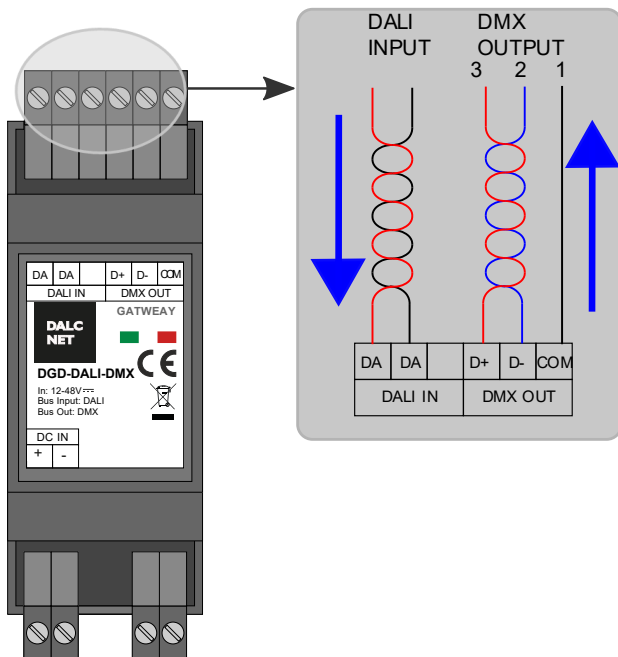

Signal LED:

In the case of no bus power detected, or bus error, the led blinks fast (2 pulsed per second).

In the case of bus power but no data, led blinks slow (1 pulse per second).

In the case of data link active, the led stands on.

Conversion

The DGD-DALI-DMX convert all 64 DALI addresses in 64 DMX Channels.

The DGD-DALI-DMX convert from DALI protocol to DMX protocol and not viceversa.

The device does not manage the addressing of DALI bus. The addresses DALI from 0 to 63 is fixed and it is sent to DMX channel from 1 to 64. The commands implemented are: OFF, UP, DOWN, STEP UP, STEP DOWN, DIRECT ARC POWER, CALL MIN LEVEL, CALL MAX LEVEL, GOTO LAST ACTIVE LEVEL. The values of the commands are not stored in the absence of the supply voltage.

Conversion Table from DALI Addresses to DMX Channels:

Addr DALI	Channel DMX	Addr DALI	Channel DMX	Addr DALI	Channel DMX	Addr DALI	Channel DMX	Addr DALI	Channel DMX	Addr DALI	Channel DMX						
+0	⇒	1	+11	⇒	12	+22	⇒	23	+33	⇒	34	+44	⇒	45	+55	⇒	56
+1	⇒	2	+12	⇒	13	+23	⇒	24	+34	⇒	35	+45	⇒	46	+56	⇒	57
+2	⇒	3	+13	⇒	14	+24	⇒	25	+35	⇒	36	+46	⇒	47	+57	⇒	58
+3	⇒	4	+14	⇒	15	+25	⇒	26	+36	⇒	37	+47	⇒	48	+58	⇒	59
+4	⇒	5	+15	⇒	16	+26	⇒	27	+37	⇒	38	+48	⇒	49	+59	⇒	60
+5	⇒	6	+16	⇒	17	+27	⇒	28	+38	⇒	39	+49	⇒	50	+60	⇒	61
+6	⇒	7	+17	⇒	18	+28	⇒	29	+39	⇒	40	+50	⇒	51	+61	⇒	62
+7	⇒	8	+18	⇒	19	+29	⇒	30	+40	⇒	41	+51	⇒	52	+62	⇒	63
+8	⇒	9	+19	⇒	20	+30	⇒	31	+41	⇒	42	+52	⇒	53	+63	⇒	64
+9	⇒	10	+20	⇒	21	+31	⇒	32	+42	⇒	43	+53	⇒	54			
+10	⇒	11	+21	⇒	22	+32	⇒	33	+43	⇒	44	+54	⇒	55			

➤ DGD-DMX-DALI SETUP – CONVERSION FROM DMX PROTOCOL TO DALI PROTOCOL

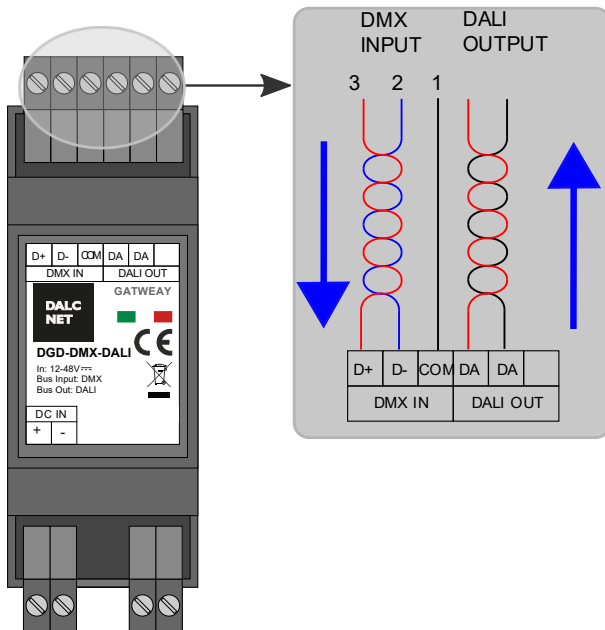

Signal LED:

- In the case of bus error, the led blinks fast (2 pulsed per second).
- In the case of no bus detected, led blinks slow (1 pulse per second).
- In the case of data link active, the led stands on.

Conversion

- The DGD-DMX-DALI convert only the first 64 DMX Channels in 64 DALI addresses.
- The DGD-DMX-DALI converter from DMX protocol to DALI protocol and not viceversa.
- The DMX channels from 1 to 64 is fixed and it is sent to DALI addresses from 0 to 63 by DIRECT ARC POWER command.

NOTE: The DGD-DMX-DALI requires power supply in the DALI bus. The devices DALI must be addressed through DALI programmer (for example with cod. DGM01-1248).

Conversion Table from DMX Channels to DALI Addresses

Channel DMX	Addr DALI	Channel DMX	Addr DALI	Channel DMX	Addr DALI	Channel DMX	Addr DALI	Channel DMX	Addr DALI	Channel DMX	Addr DALI
1	⇒ +0	12	⇒ +11	23	⇒ +22	34	⇒ +33	45	⇒ +44	56	⇒ +55
2	⇒ +1	13	⇒ +12	24	⇒ +23	35	⇒ +34	46	⇒ +45	57	⇒ +56
3	⇒ +2	14	⇒ +13	25	⇒ +24	36	⇒ +35	47	⇒ +46	58	⇒ +57
4	⇒ +3	15	⇒ +14	26	⇒ +25	37	⇒ +36	48	⇒ +47	59	⇒ +58
5	⇒ +4	16	⇒ +15	27	⇒ +26	38	⇒ +37	49	⇒ +48	60	⇒ +59
6	⇒ +5	17	⇒ +16	28	⇒ +27	39	⇒ +38	50	⇒ +49	61	⇒ +60
7	⇒ +6	18	⇒ +17	29	⇒ +28	40	⇒ +39	51	⇒ +50	62	⇒ +61
8	⇒ +7	19	⇒ +18	30	⇒ +29	41	⇒ +40	52	⇒ +51	63	⇒ +62
9	⇒ +8	20	⇒ +19	31	⇒ +30	42	⇒ +41	53	⇒ +52	64	⇒ +63
10	⇒ +9	21	⇒ +20	32	⇒ +31	43	⇒ +42	54	⇒ +53		
11	⇒ +10	22	⇒ +21	33	⇒ +32	44	⇒ +43	55	⇒ +54		